

TURN TRIM WASTE INTO PROFIT

The Electrotech Online Trim Recycler



Every Meter of Trim Waste is a Lost Revenue Opportunity.

In plastic film and extrusion manufacturing, trim is an unavoidable reality. But how you handle it has a direct and measurable impact on your bottom line.

Selling trim as scrap recoups only a fraction of its original material value, representing a continuous financial leak in your production process.



The Inefficiency of the Status Quo

Relying on the scrap market introduces multiple hidden costs and operational drags:



Massive Value Loss:

Trim is often sold for 60-70% less than the cost of virgin material.



Labor Intensive:

Requires manual collection, baling, storage, and handling, diverting staff from value-added tasks.



Space Inefficient:

Dedicated floor space must be allocated for waste storage.



Inconsistent Revenue:

Scrap prices are volatile, making financial planning difficult.

THE OLD WAY



The Solution: Reclaim 100% of Your Material Value, In-Line.

Introducing the Electrotech Online Trim Recycler.

An integrated, automated system that sits alongside your production line, instantly converting trim waste back into high-quality, reusable flakes.



From a Linear Drain to a Circular Profit Center.

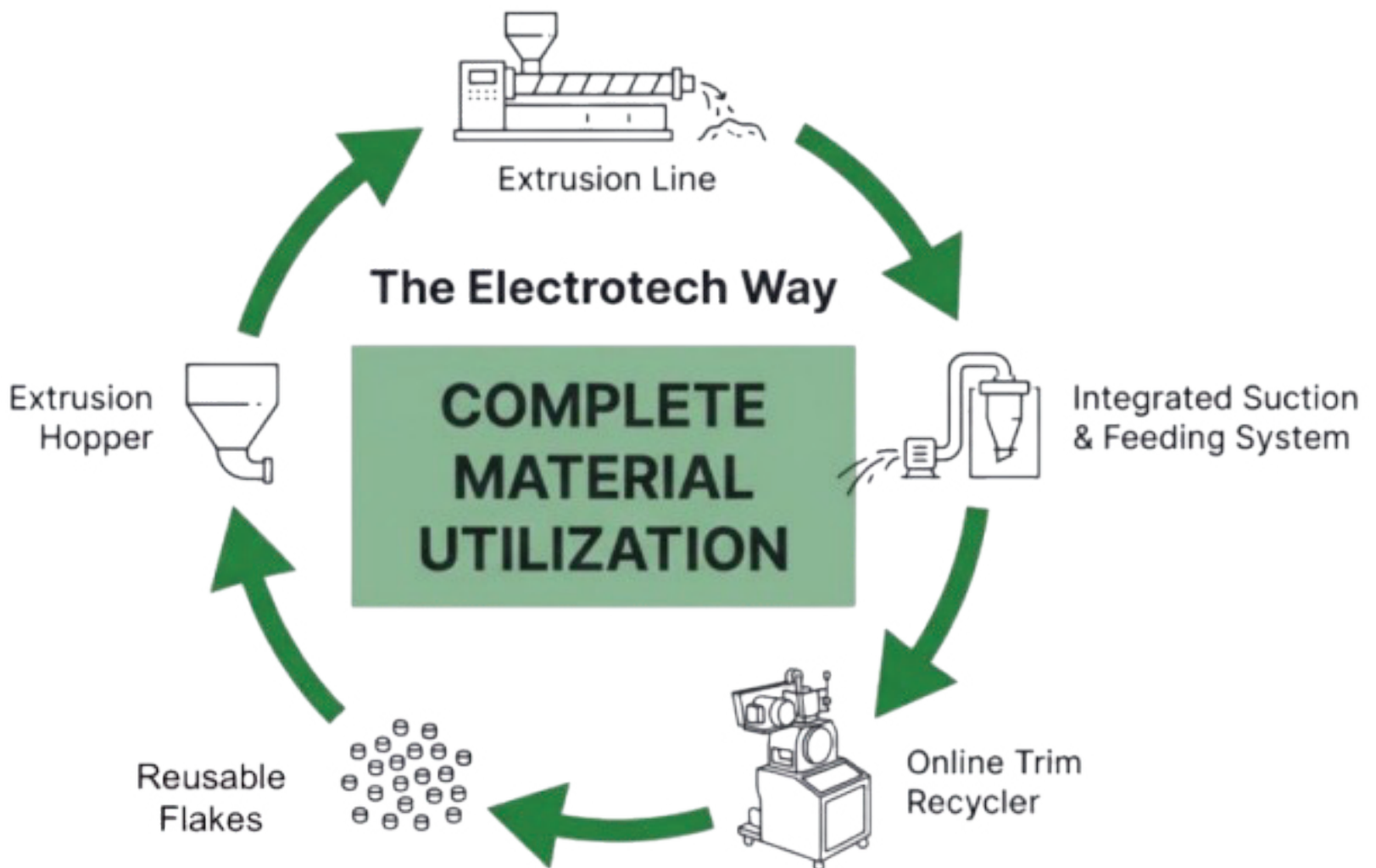

A Simple, Automated Process for Maximum Efficiency.

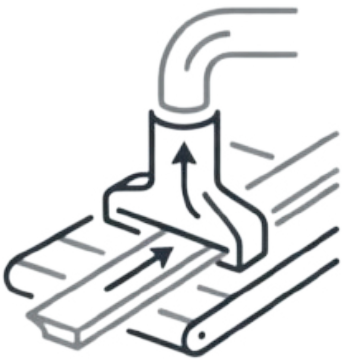

Controlled Feeding

The integrated suction system automatically captures and feeds trim directly into the unit in a controlled flow.



Efficient Shredding

The material enters the shredding unit where it is efficiently reduced into uniform, consistently sized particles.

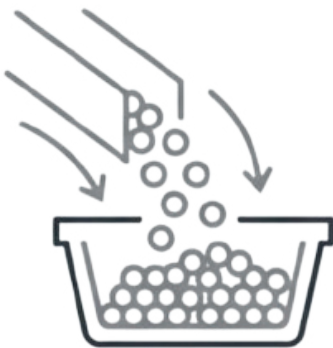

Reusable Output

The processed material is discharged as clean, reusable flakes, ready to be immediately reintroduced into your production line

UNIVERSAL INTEGRATION

Whether you are running high-speed lines or specialized thick films, the Electrotech system adapts seamlessly to your production parameters.

Line Speed Compatibility: Fully compatible with plants of all line speeds.

Material Flexibility: Works effectively for film of any thickness.

The Financial Case: A Clear Path to Increased Profitability.

Monetary Benefits Analysis
(Approximate, Per Kg of Natural Trim)

Selling as Scrap	Recycle with Electrotech
Virgin Granule Cost: 100 Rs.	Cost to Reprocess (Handling & Conversion): 0 Rs.
Sale Price of Scrap Trim: 40 Rs.	Value Recaptured: 60 Rs.
Result: 60 Rs. of Value Lost	Result: Net Gain of 60 Rs. Vs. Scrap

By investing 0 Rs. to reprocess your trim, you avoid 60 Rs. Loss - a net positive swing of 60 Rs. for every kilogram.

ROI: 2-3 Months. **(Maximum)**

With an output of 40kg per hour and substantial per-kilogram savings, the Electrotech Online Trim Recycler is not a typical capital expense. It is a high-yield investment engineered to pay for itself in a single business quarter.

Engineered for the Realities of Your Plant Floor.

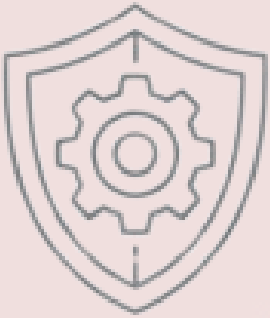

Robust Industrial Design

Guarantees maximum uptime and a long operational life in demanding production environments.

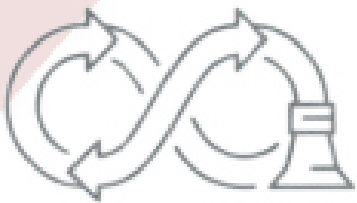

Integrated Suction & Feeding

Delivers a fully automated, seamless process from trim creation to material reclamation.



User-Friendly Controls

A simple, intuitive interface requires minimal operator training and ensures consistent, reliable operation.



Low Maintenance Operation

Designed for durability and efficiency, reducing your total cost of ownership.

Main Technical Parameters

Model	ElectroTech - Online Trim Recycler
Output	40 Kg/h
Main Motor	1.5kW
Suction Fan	1.15kW
Feeding Motor	0.4kW
Weight	285 kg
Dimensions	884 X 593 X 1014 mm

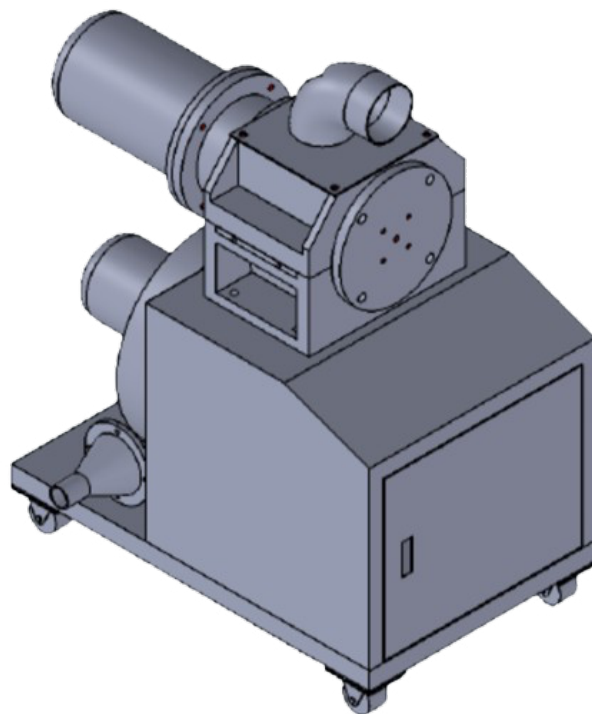

Pictorial Diagram

Stop Selling Scrap. Start Maximizing Material Value.

The Electrotech Online Trim Recycler is more than a machine-it's a strategic tool to improve your bottom line.

- **Saves Production Costs** by reducing your need for virgin material.
- **Reduces Material Waste** by immediately reusing 100% of your trim.
- **Streamlines Operations** by automating your waste handling process.
- **Delivers Rapid ROI** with a payback period of 2-3 months.





Electrotech: Your Partner in Smarter, More Profitable Manufacturing.

Stop discarding value. Integrate the Online Trim Recycler to reduce waste, lower costs, and unlock a new revenue stream from your existing production.

Contact us for a personalized ROI calculation and to learn how we can improve your operation.

Electrotech Smart Industries

145, Pushkar Industrial Estate,
Nr. Torrent Power Sub Station,
Opp. Macon's Factory, Phase-1,
G.I.D.C. Vatva,
Ahmedabad - 382445.
Gujarat, INDIA.



Email: Info@etind.com / Rakeshetind@gmail.com

Website: www.etind.com

Phone: +91-70431 76301, +91-96015 51913